

06/2023

ENGINEERED
TO MAKE YOU

smile

WORKBOOK 2024

MTB | ROAD | CITY | TOUR | CARGO | FAT
E-BIKE DRIVE SYSTEMS

POWER YOUR LIFE

BAFANG

BAFANG

POWER YOUR LIFE



CONTENT







SMART SOLUTION

BAFANG GO ⁺	↗ 4
BAFANG IOT	↗ 5

DRIVE SYSTEM RECOMMENDATION

	FOR eMTB	↗ 6
	FOR eROAD/GRAVEL	↗ 10
	FOR eCITY	↗ 11
	FOR eTOUR	↗ 13
	FOR eCARGO	↗ 14
	FOR eFAT	↗ 15

COMPONENTS

	MOTOR	↗ 16
	GEAR HUB	↗ 23
	HMI	↗ 24
	BATTERY	↗ 27
	SENSOR	↗ 30
	CONTROLLER	↗ 33
	ACCESSORIES	↗ 34

SERVICE TOOL

BESST Pro	↗ 39
-----------	------

BAFANG GO+

SMART CONNECTIVITY

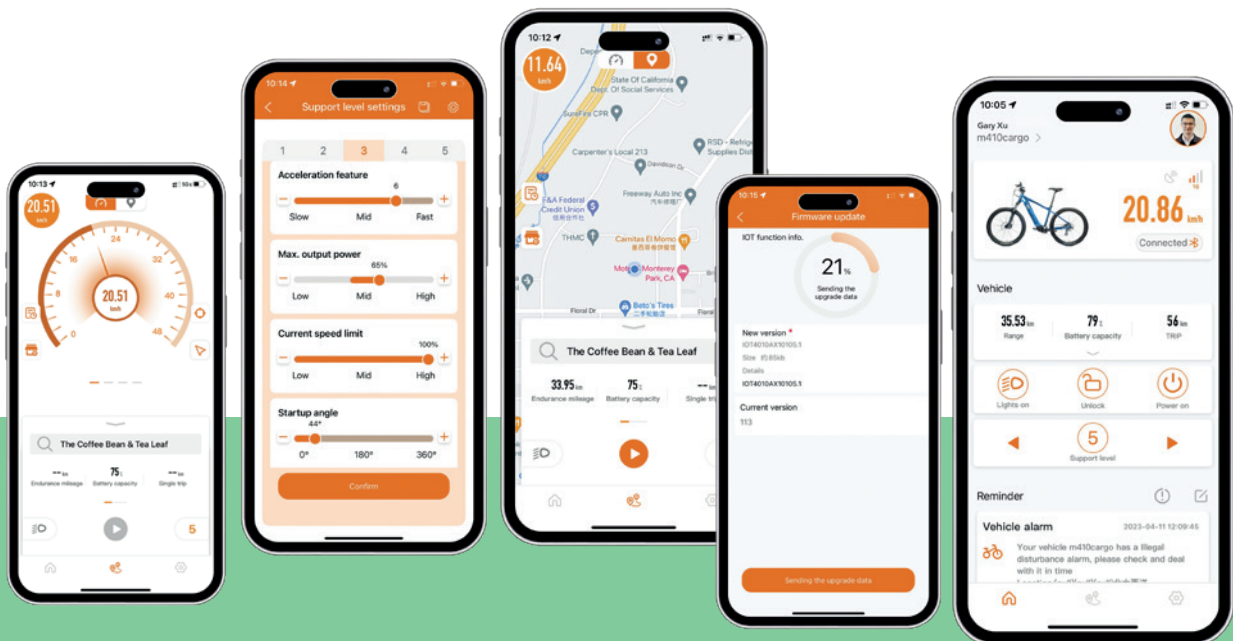

Virtual Display

Custom Settings

Riding map

Software Update

Control Interface

The upgraded smartphone app provides Bafang system users an all-round interface to enrich the cycling experience, as well as bike configuration and software update via Bluetooth. Meanwhile, the app could connect to Bafang IOT device on the smartphone, which allows users to interact with the drive systems conveniently. BAFANG GO+ for iOS™ and Android™ – right there on your phone.



iOS



Android

BAFANG IOT

INTELLIGENT CONTROL



Bafang's eBike IOT device includes innovative functions and intelligent features: 4G communication module, GPS positioning and BLE communication. Alongside these core functions come the possibility of electronic control, remote operation of various applications, anti-theft, navigation, virtual display, social media sharing, remote upgrading, and many more smart functions.

In addition to these benefits, Bafang's IOT system caters for customer-specific functions and demands, as well as common casing development. Together with our partners and customers, we are striving for new milestones in the era of intelligent link of internet-connected applications.

BAFANG M820 MID MOTOR SYSTEM

DRIVE SYSTEM FOR LIGHT ASSIST eMTB

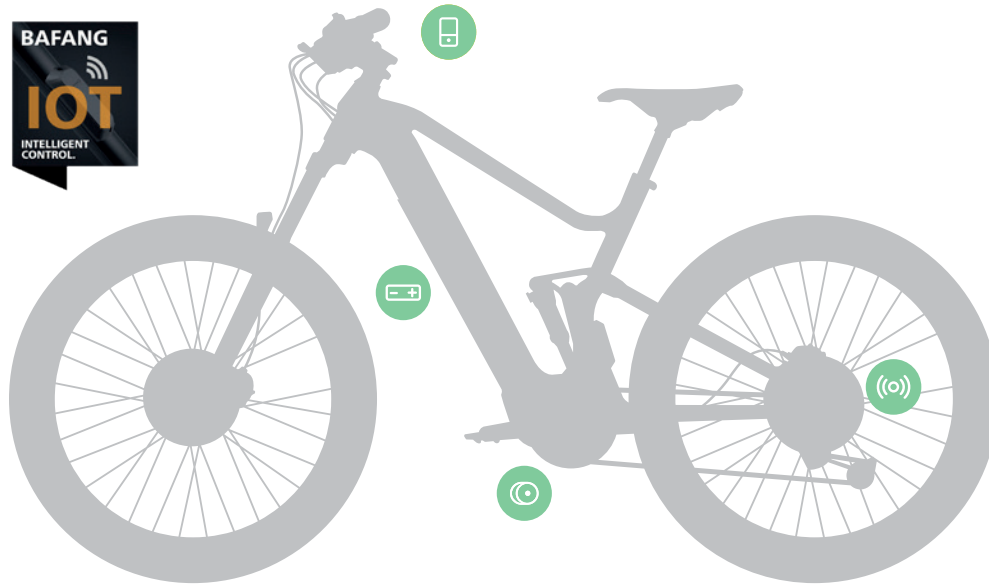

MOTOR



MM G532
250W
75N.m (Max)
Light weight < 2.3kg



HMI



DP E181
All-in-one design
Easy mounting solution



BATTERY



BT F020
Fully integrated
36V 14Ah
504Wh



BT F014
Intube
43V 9.5Ah
410Wh



SENSOR



SR SD071
Chain stay &
disc brake



SR S02
Chain stay &
disc brake with
centerlock



ACCESSORIES - Chainwheel



CW G532.1A
44T, CL49



ACCESSORIES - Crank



CK ISIS01.170P/165P



ACCESSORIES - Fixation Parts/Motor Cover/Bash Guard



FP MMG532.A
Fixation parts



MD G532.A
Motor cover



BG G532.A
Bash guard



FP MMG532.B
Fixation parts



MD G532.B
Motor cover



BG G532.A
Bash guard



BAFANG M560 MID MOTOR SYSTEM

DRIVE SYSTEM FOR HEAVY ASSIST eMTB



MOTOR



MM G5300
500W
130N.m (Max)
Light weight < 3.3kg



HMI



DP C245
1.9" TFT display
Full-fit screen



BATTERY



BT F311
Fully integrated
48V 17.5Ah
840Wh



SENSOR



SR SD071
Chain stay &
disc brake



SR S02
Chain stay &
disc brake with
centerlock



ACCESSORIES - Chainwheel



CW G522.1A
32/40T, CL53



CW G522.1C
34T, CL53



ACCESSORIES - Crank



CK BF01.170P **CK BF02.170P** **CK BF02.165P**



ACCESSORIES - Fixation Parts/Motor Cover/Bash Guard



FP MMG521.B
Fixation parts



MD G521.B
Motor cover



BG G521.B
Bash guard



BAFANG M510 MID MOTOR SYSTEM

DRIVE SYSTEM FOR ALL TERRAIN eMTB



MOTOR



MM G522
250W
95N.m (Max)
Light weight < 2.9kg



HMI



DP C010
4.0" TFT display
Full-fit screen
Multi UI options
6 languages



DP C245
1.9" TFT display
Full-fit screen



BATTERY



BT F15
Fully integrated
36V 24.5Ah
882Wh



SENSOR



SR SD071
Chain stay &
disc brake



SR S02
Chain stay &
disc brake with
centerlock



ACCESSORIES - Chainwheel



CW G522.1A
32/40T, CL53



CW G522.1C
34T, CL53



ACCESSORIES - Crank



CK BF01.170P



CK BF02.170P/165P



ACCESSORIES - Fixation Parts/Motor Cover/Bash Guard



FP MMG521.B
Fixation parts



MD G522.A
Motor cover



BG G521.B
Bash guard



BAFANG H640 REAR DRIVE SYSTEM

DRIVE SYSTEM FOR OUTDOOR UTILITY eMTB

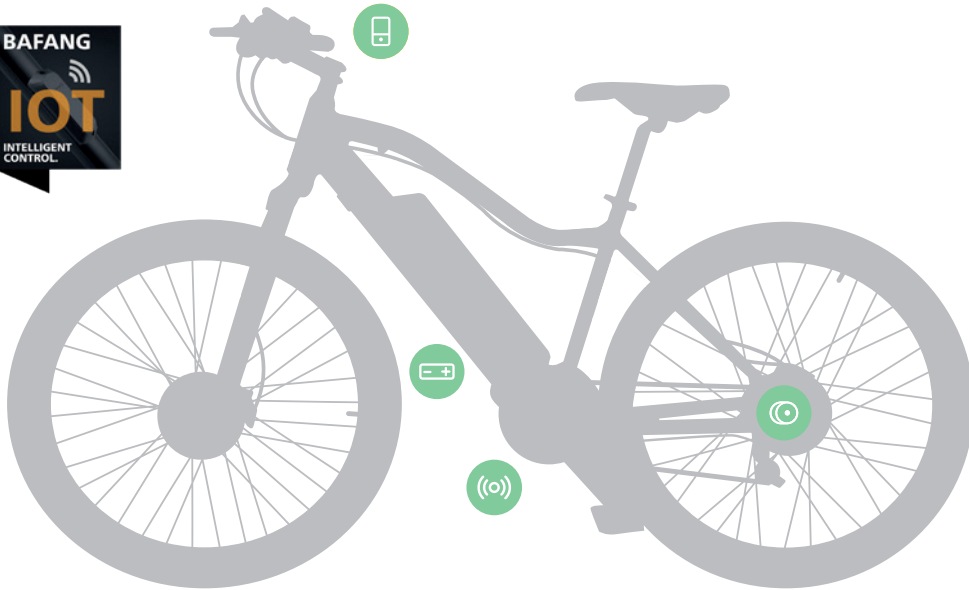

MOTOR



RM G0900
750W
80N.m (Max)



HMI



DP C220
Easy to operate
2.0" LCD display



BATTERY



BT F150
Semi integrated/
on tube
36V 17.5Ah, 630Wh



BT F311
Fully integrated
48V 17.5Ah
840Wh



SENSOR



SR PA211.32.ST
Torque & cadence
sensor



CONTROLLER



CR S307.1000.FC



BAFANG M820 MID MOTOR SYSTEM

DRIVE SYSTEM FOR eRoad



MOTOR



MM G532
250W
75N.m (Max)
Light weight < 2.3kg



HMI



DP C263
2.4" TFT display
2 button options
UI for eROAD



BATTERY



BT F050
Fully integrated
36V 10Ah
360Wh



BT F014
Intube
43V 9.5Ah
410Wh

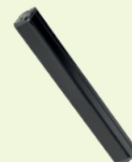

SENSOR



SR SD071
Chain stay &
disc brake



SR S02
Chain stay &
disc brake with
centerlock



ACCESSORIES - Chainwheel



CW G532.1A
44T, CL49



ACCESSORIES - Crank



CK ISIS01.170P



ACCESSORIES - Fixation Parts/Motor Cover/Bash Guard



FP MMG532.A
Fixation parts



MD G532.A
Motor cover



BG G532.A
Bash guard



FP MMG532.B
Fixation parts



MD G532.B
Motor cover



BG G532.A
Bash guard



BAFANG M210 MID MOTOR SYSTEM

DRIVE SYSTEM FOR eCity



MOTOR



MM G2300
250W
70N.m (Max)



HMI



DP C010
4.0" TFT display
Full-fit screen
Multi UI options
6 languages



DP C220
2.0" LCD display
Easy to operate



BATTERY



BT C01
Rear carrier
43V 11.6Ah
498Wh



BT F010
Fully integrated
36V 17.5Ah
630Wh



BT F020/021
Fully integrated
36V 14Ah
504Wh



GEAR HUB



RG A310.S.D
3-speed
automatic gear hub



ACCESSORIES - Sprocket wheel



SW A310.01.A(16/18/20/22T)



ACCESSORIES - Chainwheel



CW G210.1B
38 / 44T , CL 45



CW G210.1C
38T , CL 48



ACCESSORIES - Fixation Parts/Motor Cover/Bash Guard



FP MMG2300.A
Fixation parts



MD G210.A
Motor cover



ACCESSORIES - Crank



CK JIS03.170P



CK JIS01.170P



BAFANG H700 REAR DRIVE SYSTEM

DRIVE SYSTEM FOR eCity



eCity

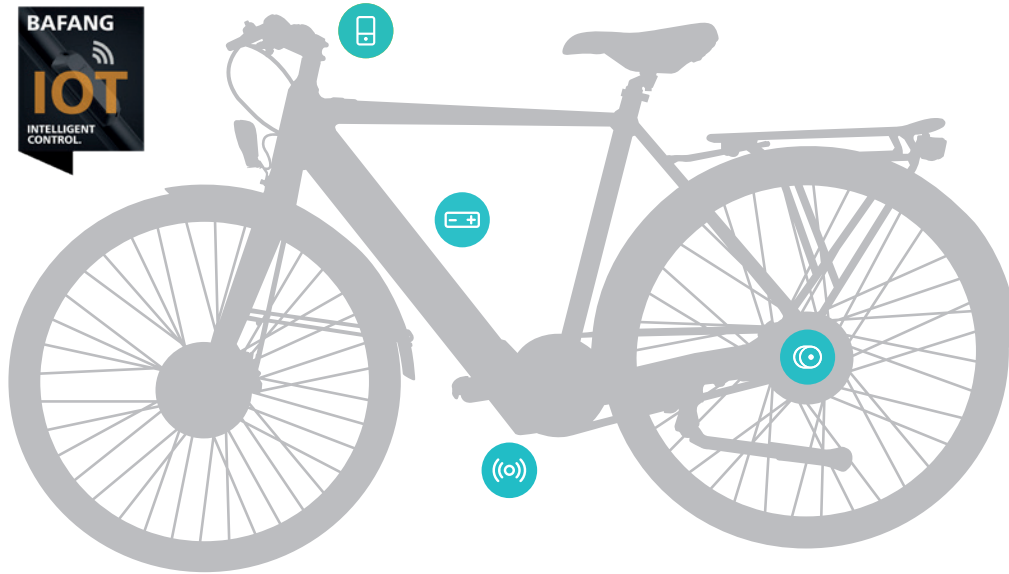

MOTOR



RM G3600
250W
40N.m (Max)
Auto dual speed integrated
Belt/Chain optional



HMI



DP E171
One button display
Integrated on frame



BATTERY



BT F020/021 Fully integrated 36V 14Ah 504Wh	BT F041 Intube 36V 10Ah 360Wh
---	---



SENSOR



SR PA211.32.ST
Torque & cadence
sensor



CONTROLLER



CR A101.C



ACCESSORIES - Sprocket wheel



SW G3600.01.A(16T)
SW A310.01.A(16/18/20/22T)
SW A310.01.B(18/20T)



BAFANG M410 MID MOTOR SYSTEM

DRIVE SYSTEM FOR eTour (eSUV)

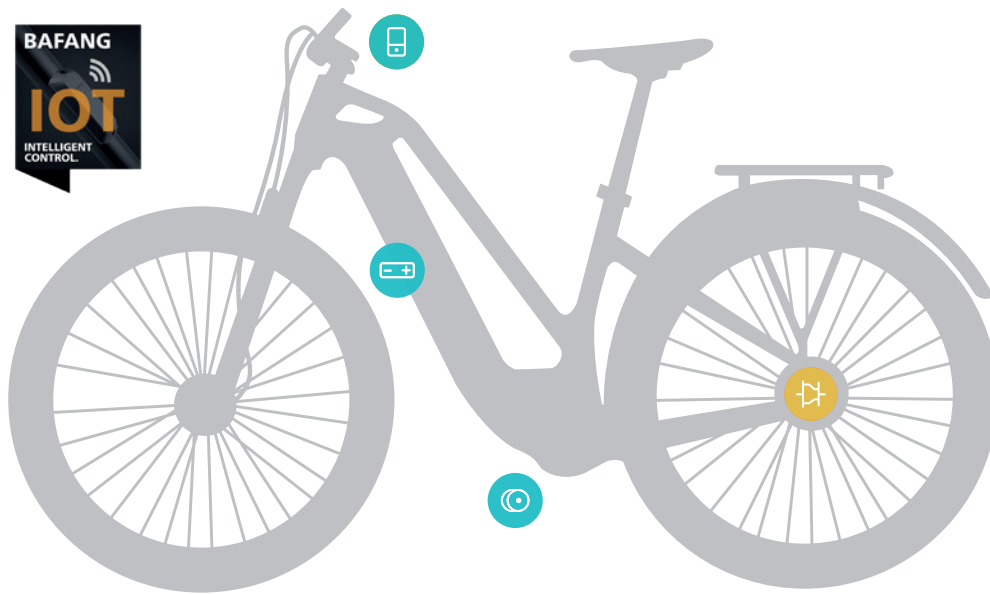

MOTOR



MM G333
250W
80N.m (Max)



HMI



DP C010
4.0" TFT display
Full-fit screen
Multi UI options
6 languages



DP C245
1.9" TFT display
Full-fit screen



BATTERY



BT F010
Fully integrated
36V 14Ah
630Wh



BT F15
Fully integrated
36V 24.5Ah
882Wh



GEAR HUB



RG A310.S.D
3-speed
automatic gear hub



ACCESSORIES - Sprocket wheel



SW A310.01.A(16/18/20/22T)



ACCESSORIES - Chainwheel



CW G333.1B
38T, CL 53



ACCESSORIES - Fixation Parts/Motor Cover/Bash Guard



FP MMG521.B
Fixation parts



MD G333.B
Motor cover



BG G333.B
Bash guard



ACCESSORIES - Crank



CK JIS01.170P



BAFANG M410 MID MOTOR SYSTEM

DRIVE SYSTEM FOR eCargo



eCargo

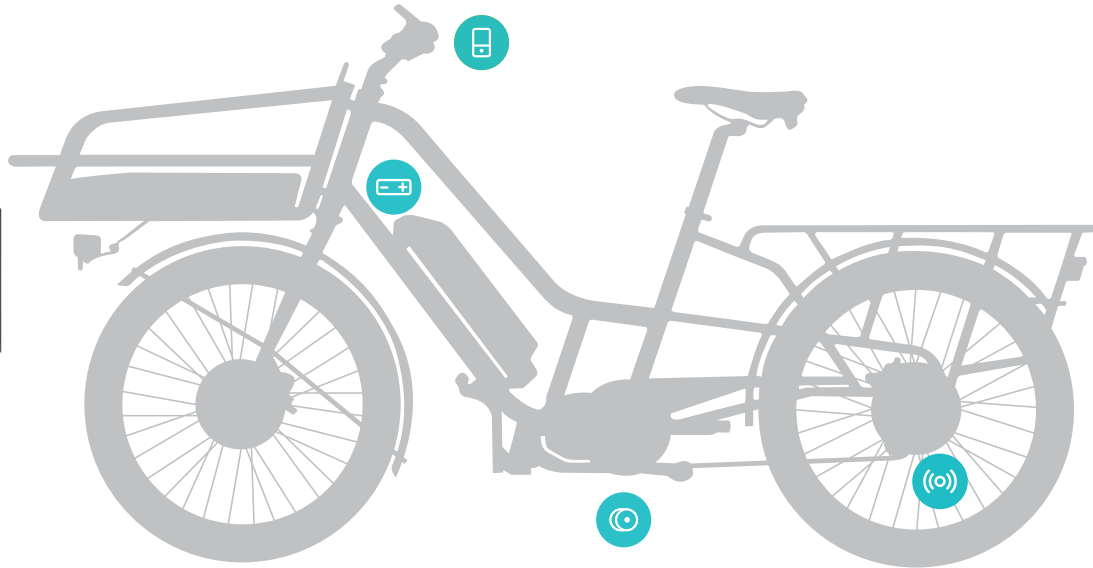

MOTOR



MM G333
250W
80N.m
3.3kg



HMI



DP C020
3.5" LCD segment
Full-fit screen
5-key control unit



BATTERY



BT F07
Semi integrated/ontube
43V 11.6Ah
498Wh



SENSOR



SR SD021
Chain stay & spoke
mounting



ACCESSORIES - Chainwheel



CW G333.1B
38T , CL 53



ACCESSORIES - Crank



CK JIS01.170P



ACCESSORIES - Fixation Parts/Motor Cover/Bash Guard



FP MMG521.B
Fixation parts



MD G333.B
Motor cover



BG G333.B
Bash guard



BAFANG H550 REAR DRIVE SYSTEM

DRIVE SYSTEM FOR eFat

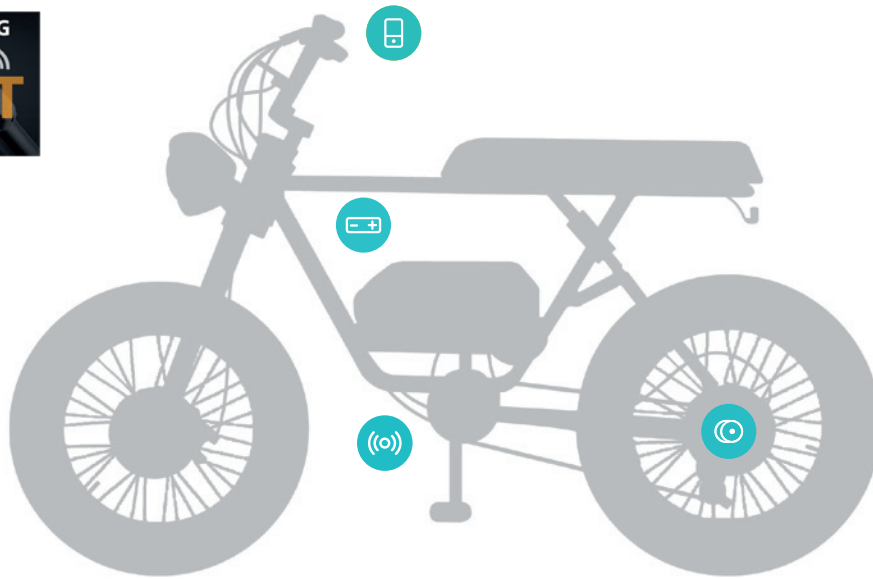

MOTOR



RM G062/RM G063
750, 1000W
80, 95N.m(Max)



HMI



DP C220
2.0" LCD display
Easy to operate



BATTERY



BT F150
Semi integrated/
ontube
36V 17.5Ah
630Wh



SENSOR



SR PA142.32.S
Cadence sensor

SR PA051.12.S
Cadence sensor



CONTROLLER



CR S307.1000.FC



MOTOR

Mag



Mag

NEW



Mag







M820

M620

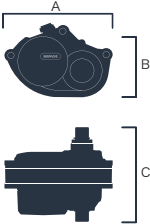
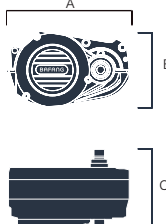
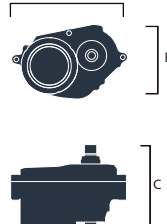
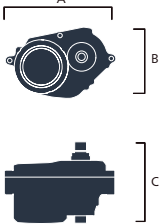
M560

M510

Position	Mid Motor	Mid Motor	Mid Motor	Mid Motor
Model No.	MM G532.250.C	MM G510.750.C MM G510.1000.C	MM G5300.500.C	MM G522.250.C
Application	eRoad , eGravel , eMTB	eCargo , eFat	eCargo , eMTB , eSpeed	eMTB
Dimensions/ Size				
				
A (mm)	167	235	197	197
B (mm)	117	138	125	125
C (mm)	147.6	150	154.8	154.8
Core Data				
Wheel Size (Inch)	20 - 29	20 - 29	20 - 29	20 - 29
Nominal Voltage (Vdc)	36 / 43 / 48	48 / 52	48	36 / 43 / 48
Rated Power (W)	250	750 , 1000	500	250
Speed Limit (km/h)	25 / 32 / 45	25 / 32 / 45	25 / 32 / 45	25 / 32
Max Torque (N.m)	75	160	130	95
Pedal Sensor	Cadence & Torque	Cadence & Torque	Cadence & Torque	Cadence & Torque
Shaft Standard	ISIS	ISIS	BAFANG	BAFANG
Color	Black	Black	Black	Black
Weight (kg)	2.3	6.7	3.3	2.9
Function				
Smart mode*	-	-	Yes	Yes
E-Brake	Optional	Optional	Optional	Optional
Throttle	N/A	Optional	Optional	N/A
Light Drive Capacity (Vdc/W)	12 / 6(max)	12 / 12(max)	12 / 6(max)	12 / 6(max)
Chain Guide	-	-	ISCG05	ISCG05
Tests & Certifications	IP X6 CE / EN 14766 / ROHS	IP X5 CE / EN 14766 / ROHS / UL2849	IP X6 CE / EN 14766 / ROHS / UL2849	IP X6 CE / EN 14766 / ROHS

MOTOR



M420

M410

M210

Position	Mid Motor	Mid Motor	Mid Motor
Model No.	MM G332.250.C MM G332.250.CCB	MM G333.250.C MM G3300.350.C	MM G2300.250.C
Application	eCity , eTour	eMTB , eCargo , eSUV	eCity , eTour
Dimensions/ Size			
A (mm)	202	197	206
B (mm)	123	125	145
C (mm)	154.8	153	150
Core Data			
Wheel Size (Inch)	20 - 29	20 - 29	20 - 29
Nominal Voltage (Vdc)	36 / 43 / 48	36 / 43 / 48	36 / 43 / 48
Rated Power (W)	250	250 , 350	250
Speed Limit (km/h)	25 / 32	25 / 32	25 / 32
Max Torque (N.m)	80	80 , 90	70
Pedal Sensor	Cadence & Torque	Cadence & Torque	Cadence & Torque
Shaft Standard	BAFANG	JIS	JIS
Color	Black	Black	Black
Weight (kg)	3.6	3.3	3.2
Function			
Smart mode*	-	-	Yes
E-Brake	Optional	Optional	Optional
Throttle	N/A	N/A , Optional	N/A
Light Drive Capacity (Vdc/W)	6 / 3(max)	12 / 6(max)	12 / 6(max)
Chain Guide	6 bolt	6 bolt	6 bolt
Tests & Certifications	IP X5 CE / EN 14766 / ROHS	IP X6 CE / EN 14766 / ROHS / UL2849	IP X6 CE / EN 14764 / ROHS

* Change assist ratio automatically according to rider's output.

MOTOR

Mag NEW



M635

Position	Mid Motor
Model No.	MM G3600.1000.C
Application	eCargo , eFat

Mag NEW



M435

Position	Mid Motor
Model No.	MM G3610.500.C MM G3610.750.C
Application	eCargo , eFat , eTour

Mag



M225

Position	Mid Motor
Model No.	MM G341.250.C
Application	eCity , eTour , eFat

Dimensions/ Size

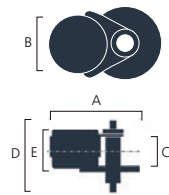
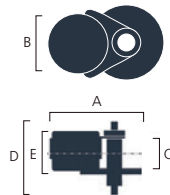
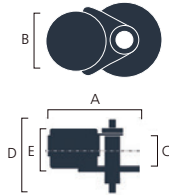

A (mm)	216	216	216
B (mm)	154	154	154
C (mm)	68 / 73	68 / 73	68
D (mm)	174	174	174
E (mm)	132.5	110.5	110.5
Core Data			
Wheel Size (Inch)	20 - 29	20 - 29	20 - 29
Nominal Voltage (Vdc)	48	48	36 / 48
Rated Power (W)	1000	500 , 750	250
Speed Limit (km/h)	25 / 32 / 45	25 / 32	25 / 32
Max Torque (N.m)	160	135	80
Pedal Sensor	Cadence & Torque	Cadence & Torque	Cadence
Shaft Standard	JIS	JIS	JIS
Color	Black	Black	Black
Weight (kg)	5.4	4.4	4
Function			
Smart mode*	-	-	-
E-Brake	Optional	Optional	Optional
Throttle	Optional	Optional	Optional
Light Drive Capacity (Vdc/W)	12 / 6(max)	12 / 6(max)	12 / 6(max)
Chain Guide	N/A	N/A	N/A
Tests & Certifications			
	IP X6 CE / EN 14764 / ROHS	IP X6 CE / EN 14764 / ROHS	IP X6 CE / EN 14764 / ROHS

MOTOR

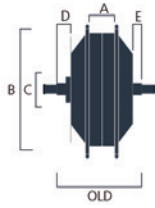

H600

H550

H400

Position	Front Motor	Front Motor	Front Motor
Model No.	FM G370.250.D/V	FM G0200.250.D FM G0200.500.D FM G0200.750.D	FM G312.250.D/V
Application	eCity	eFat , eCargo	eCity
Size			
A (mm)	45	68	37
B (mm)	91	145	121
C (mm)	44	44	44
D (mm)	10.5	10.5	10.5
E (mm)	2.6	12	4.7
OLD (mm)	100	135	100
Core Data			
Wheel Size (Inch)	26 / 700C / 28	20 , 26	16 - 24
Nominal Voltage (Vdc)	36 / 43	36 / 48(Fat tire)	36
Rated Power (W)	250	250 , 500 , 750	250
Max Speed (km/h)	25	25 , 25 / 32	25
Max Torque (N.m)	30	55 , 65 , 85	45
Color	Silver / Black	Silver / Black	Silver / Black
Weight (kg)	1.7	3.8 / 4.2 / 4.7	2.4
Mounting Parameters			
Brake	Disc-Brake , V-Brake	Disc-Brake	Disc-Brake , V-Brake
Cabling Route	Shaft Side_Left	Shaft Side_Left	Shaft Side_Right
Cable Length(mm), Connection Type	250 G9.1	250G9.1 , 250G9.14.2 , 250G11.2	250 G9.1
Spoke Specification	36H*13G	36H*12G	36H*13G
Throttle	N/A	N/A	N/A
Tests & Certifications	IP X5 ROHS / CE	IP X6 ROHS / CE	IP X6 ROHS / CE

MOTOR

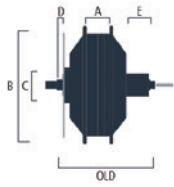

H720

H710

H700

Position	Rear Motor	Rear Motor	Rear Motor
Model No.	RM G06A2.250.D RM G06A2.500.D RM G06A2.750.D RM G06A2.1000.D	RM G02A2.250.D RM G02A2.350.D	RM G3600.250.A2.D
Application	eFat	eCity , eTour	eCity
Size			
A (mm)	68	45	45
B (mm)	145	145	123
C (mm)	44	44	44
D (mm)	15.25	15.25	15.25
E (mm)	26	7.5	10
OLD (mm)	175	142	138
Core Data			
Wheel Size (Inch)	20 / 26(Fat tire)	26 / 700C / 28	26 / 700C / 28
Nominal Voltage (Vdc)	48 , 48 , 48 / 52 , 48 / 52	36 / 48 , 48	36 / 43
Rated Power (W)	250 , 500 , 750 , 1000	250 , 350	250
Max Speed (km/h)	25 / 32 , 32 / 45 , 45 , 45 / 45+	25 / 32	25 / 32
Max Torque (N.m)	55 , 65 , 80 , 95	45 , 50	40
Color	Black	Black	Black
Weight (kg)	4.8 , 5.1 , 5.4 , 5.4	4.1	3.2
Mounting Parameters			
Brake	Disc-Brake	Disc-Brake	Disc-Brake
Cabling Route	Shaft Side_Left	Shaft Side_Left	Shaft Side_Left
Cable Length(mm), Connection Type	250 G9.1 , 250 G9.14.2 , 250 G11.2 , 250 G11.6	250 G9.1	250 G9.1
Spoke Specification	36H*13G , 36H*12G , 36H*12G , 36H*12G	36H*13G	36H*13G
Sprocket Wheel	Single - 16T / 18T / 20T / 22T	Single - 16T / 18T / 20T / 22T	Single - 16T / 18T / 20T
Throttle	Optional	Optional	N/A
Special Function	Automatic Dual Speed	Automatic Dual Speed	Automatic Dual Speed
Tests & Certifications	IP X6 ROHS / CE / UL2849	IP X6 ROHS / CE / UL2849	IP X6 ROHS / CE / UL2849

MOTOR

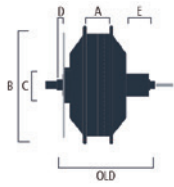

H640

H625

H600

H550

Position	Rear Motor	Rear Motor	Rear Motor	Rear Motor
Model No.	RM G0900.750.D/DC RM G0900.750.C.DC	RM G0700.500.D/DC	RM G370.250.DC	RM G063.1000.D/DC
Application	eMTB , eCargo , eSpeed	eMTB , eCargo , eSpeed	eRoad , eCity	eFat , eCargo
Size				
A (mm)	32	35.5	44	68
B (mm)	183	170	93	145
C (mm)	44	44	44	44
D (mm)	15.25	15.25	15.25	15.25
E (mm)	40.75	40	39.5	42.7
OLD (mm)	138	138	148	175
Core Data				
Wheel Size (Inch)	26 / 700C / 28	26 / 700C / 28	26 / 700C / 28	20 / 26
Nominal Voltage (Vdc)	48	36 / 48	36 / 43	48 / 52(Fat tire)
Rated Power (W)	750	250 / 500	250	1000
Max Speed (km/h)	45	25 / 32	25	45 / 45+
Max Torque (N.m)	80	50 / 60	30	95
Color	Silver / Black	Black	Black	Black
Weight (kg)	5.6	4.8	2.0	4.9
Mounting Parameters				
Brake	Disc-Brake	Disc-Brake	Disc-Brake	Disc-Brake
Cabling Route	Shaft Side_Left	Shaft Side_Left	Shaft Side_Left	Shaft Side_Left
Cable Length(mm), Connection Type	250 G11.6	250 G9.14.2	250 G9.1	250 G11.6
Spoke Specification	36H*12G	36H*12G	36H*13G	36H*12G
Sprocket Wheel	8 - 10	8 - 10	8 -10	8 - 10
Throttle	Optional	Optional	N/A	Optional
Special Function	Cadence sensor integrated (RM G0900.750.C.DC)	-	-	-
Tests & Certifications	IP X6 ROHS / CE / UL2849	IP X6 ROHS / CE	IP X6 ROHS / CE	IP X6 ROHS / CE / UL2849

MOTOR



H550W

Position	Rear Motor
Model No.	RM G0F2.750.D/DC RM G0F4.1000.D/DC
Application	eFat , eCargo
Size*	
A (mm)	74
B (mm)	422
C (mm)	44
D (mm)	15.25
E (mm)	48, 52
OLD (mm)	175
Core Data	
Wheel Size (Inch)	20(Fat tire)
Nominal Voltage (Vdc)	48 / 52, 48 / 52
Rated Power (W)	750, 1000
Max Speed (km/h)	32 / 45, 45 / 45+
Max Torque (N.m)	80, 95
Color	Black
Weight (kg)	8
Mounting Parameters	
Brake	Disc-Brake
Cabling Route	Shaft Side_Left
Cable Length (mm), Connection Type	250 G9.1 , 250 G11.6
Spoke Specification	NA
Sprocket Wheel	6 - 7, 8 - 10
Throttle	Optional
Tests & Certifications	IP X5 ROHS / CE

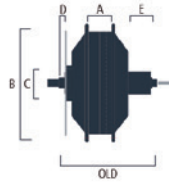

H405

Position	Rear Motor
Model No.	RM G0210.250.D/DC RM G0210.350.D/DC
Application	eCity , eTour , eMTB
Size	
A (mm)	42.5
B (mm)	145
C (mm)	44
D (mm)	15.25
E (mm)	39
OLD (mm)	143
Core Data	
Wheel Size (Inch)	700C / 28
Nominal Voltage (Vdc)	36, 48
Rated Power (W)	250, 350
Max Speed (km/h)	25, 25 / 32
Max Torque (N.m)	50 / 55
Color	Black
Weight (kg)	3.3
Mounting Parameters	
Brake	Disc Brake
Cabling Route	Shaft Side_Left
Cable Length(mm), Connection Type	250 G9.1
Spoke Specification	36H*13G
Sprocket Wheel	7 - 9
Throttle	Optional
Tests & Certifications	IP X6 ROHS / CE



H305

Position	Rear Motor
Model No.	RM G0100.250.D/DC RM G0100.350.D/DC
Application	eCity , eTour
Size	
A (mm)	41
B (mm)	127
C (mm)	44
D (mm)	15.25
E (mm)	40
OLD (mm)	138
Core Data	
Wheel Size (Inch)	26 / 700C / 28
Nominal Voltage (Vdc)	36 / 48
Rated Power (W)	250, 350
Max Speed (km/h)	25, 25 / 32
Max Torque (N.m)	45 / 50
Color	Black
Weight (kg)	3.1
Mounting Parameters	
Brake	Disc Brake
Cabling Route	Shaft Side_Left
Cable Length(mm), Connection Type	250 G9.1
Spoke Specification	36H*13G
Sprocket Wheel	8 - 10
Throttle	N/A
Tests & Certifications	IP X6 ROHS / CE

GEAR HUB

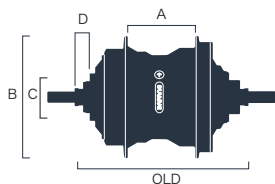

NEW



NEW

Model No.	RG A310.S.D	RG A510.D
Position	Rear Wheel	Rear Wheel
Application	eCity / eTour	eFat
Size		
A (mm)	50	71
B (mm)	87	110
C (mm)	44	44
D (mm)	15.25	15.25
OLD (mm)	135	175 / 190
Core Data		
Gearshift Method	Auto	Auto
Gear No.	3	5
Reduction ratio	1 : 1.30 : 1.65	1 : 1.33 : 1.81 : 2.46 : 3.35
Max Allowable Torque (N.m)	85	200
Wheel Size (Inch)	16 / 20 / 24 / 26 / 700C / 28	20 / 26(Fat tire)
Color	Silver / Black	Red / Black
Weight (kg)	1.7	3.7
Mounting Parameters		
Brake	Disc-Brake	Disc-Brake
Wheel Speed Sensor	Optional	-
Cabling Route	Shaft Side_Left / -	-
Cable Length(mm), Connection Type	500 G4.3 / 3104A1004 / -	-
Spoke Specification	36H*13G	36H*12G
Sprocket Wheel	Single - 16T / 18T / 20T / 22T , Belt	Single - 26T / 30T
Tests & Certifications	Waterproof: IP X6	Certifications: ROHS / CE

HMI



Model No.	DP C010.C DP C010.CB	DP C270.CAN DP C271.CAN	DP C263.CAN	DP C244.CAN DP C245.CAN
Dimensions/ Size				
A (mm)	59.5	68	51.3	57
B (mm)	98.8	90.3	79.2	73.3
C (mm)	60 - 82	51 - 84.5	-	43.5
D (mm)	Ø 35	Ø 31.8	-	Ø 35
E (mm)	51.8	43.2	37.5	42.7
F (mm)	86.4	57.6	49.7	22.7
G (Inch)	4.0"	2.8"	2.4"	1.9"
Core Data				
Display Type	TFT	TFT	TFT	TFT
Nominal Voltage (Vdc)	36 / 43 / 48 / 52	36 / 43 / 48 / 52	36 / 43 / 48 / 52	36 / 43 / 48
Support Modes	4 modes / 6 modes	0 - 5	0 - 5	4 modes / 6 modes
Mounting Parameters				
Holder Diameter (mm)	Ø 22.2 / 25.4 / 31.8 / 35	Ø 22.2 / 25.4 / 31.8	-	Ø 25.4 / 31.8 / 35
Cable Length (mm), Connector Type	230 G5.4 / 850 G5.4	0 G5.4	230 G5.4 / 850 G5.4	0 G5.4
Control Unit Cable (mm)	300 / 250	300 / 250	300 / 350	300 / 350
Functions				
ON/OFF	●	●	●	●
Mode	●	●	●	●
Light Control	Auto / Manual	Auto / Manual	Manual	Auto / Manual
Walk Assistance	●	●	●	●
Bluetooth 5.0	✕ ●	✕ ●	●	✕ ●
USB Charge	5V 1A (Type C)	5V 500mA (Type A)	✕	5V 500mA (Type C)
Clock	●	●	✕	✕
Setting	●	●	●	●
Indications				
Error Code	●	●	●	●
Power	●	●	●	●
UI Options	3	3	1	1
Languages	EN / DE / NL / FR / IT / CZ	EN / DE / NL / FR / IT / CZ	EN	EN
Tests & Certifications	IP X6 CE / EN 15194 / UL2849 / REACH / ROHS	IP X6 CE / EN 15194 / REACH / ROHS	IP X5 CE / EN 15194 / REACH / ROHS	IP X6 CE / EN 15194 / UL2849 / REACH / ROHS

HMI

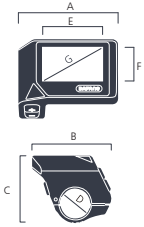
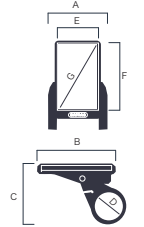
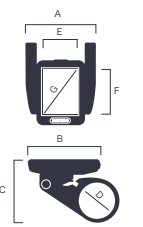

Model No.	DP C220.CAN DP C221.CAN	DP C020.C	DP C380.CAN DP C381.CAN
Dimensions/ Size			
A (mm)	74	58.4	68.7
B (mm)	59	98.4	81.1
C (mm)	51	75.7	56.4
D (mm)	Ø 22.2	Ø 35	Ø 31.8
E (mm)	46	44.4	33
F (mm)	24	76	42.5
G (Inch)	2"	3.5"	2"
Core Data			
Display Type	LCD Matrix	LCD Segment + Matrix	LCD Segment
Nominal Voltage (Vdc)	36 / 43 / 48	36 - 60	36 - 60
Support Modes	0 - 3 / 0 - 5	0 - 5	0 - 5
Mounting Parameters			
Holder Diameter (mm)	Ø 22.2	Ø 22.2 / 25.4 / 31.8 / 35	Ø 22.2 / 25.4 / 31.8
Cable Length (mm), Connector Type	230 G5.4 / 850 G5.4	230 G5.4	230 G5.4.2 / 850 G5.4.2
Control Unit Cable (mm)	-	300 / 350	300
Functions			
ON/OFF	●	●	●
Mode	●	●	●
Light Control	Manual	Auto / Manual	Auto / Manual
Walk Assistance	●	●	●
Bluetooth 5.0	✗ ●	✗	● ✗
USB Charge	✗	✗	✗
Clock	✗	✗	✗
Setting	●	●	●
Indications			
Error Code	●	●	●
Power	●	●	●
UI Options	1	1	1
Languages	EN	EN	EN
Tests & Certifications	IP X5 CE / EN 15194 / UL2849 / REACH / ROHS	IP X5 CE / EN 15194 / REACH / ROHS	IP X6 CE / EN 15194 / REACH / ROHS

HMI

NEW



Model No.	DP E165.CAN	DP E160.CAN DP E161.CAN	DP E180.CAN DP E181.CAN	DP E170.CAN DP E171.CAN
Dimensions/ Size				
A (mm)	23.3	23	31.5	30
B (mm)	58.5	45.2	51	46
C (mm)	19	49.3	52.2	39.4
D (mm)	-	Ø 22.2	Ø 22.2	18
E (mm)	-	-	-	29.6
Core Data				
Display Type	LED	LED	LED	LED
Nominal Voltage (Vdc)	36 / 43 / 48	36 / 43 / 48	36 / 43 / 48	36 / 43 / 48
Support Modes	0 - 5	0 - 5	0 - 5	1 - 3
Mounting Parameters				
Holder Diameter (mm)	-	Ø 22.2	Ø 22.2	-
Cable Length (mm), Connector Type	230 G5.4.2 / 850 G5.4.2	230 G5.4.2 / 850 G5.4.2	230 G5.4.2 / 850 G5.4.2	300 G5.4 / 850 G5.4
Control Unit Cable (mm)	-	-	-	-
Functions				
ON/OFF	●	●	●	●
Mode	●	●	●	●
Light Control	Auto / Manual	Auto / Manual	Auto / Manual	Manual
Walk Assistance	✗	●	●	✗
Bluetooth 5.0	●	✗ ●	✗ ●	✗ ●
USB Charge	✗	✗	✗	✗
Clock	✗	✗	✗	✗
Setting	✗	✗	✗	✗
Indications				
Error Code	●	●	●	●
Power	✗	✗	✗	✗
UI Options	✗	✗	✗	✗
Languages	-	-	-	-
Tests & Certifications	IP X6 CE / EN 15194 / REACH / ROHS	IP X6 CE / EN 15194 / REACH / ROHS	IP X5 CE / EN 15194 / REACH / ROHS	IP X6 CE / EN 15194 / REACH / ROHS

BATTERY

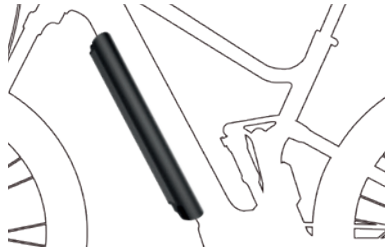

Model No.	BT F050.B360.C.P	
Dimensions/Size		
A (mm)	459	
B (mm)	57	
C (mm)	60	
Specifications		
Nominal Voltage (Vdc)	36	
Energy (Wh)	360	
Rated Capacity (Ah)	10	
S	10	
P	2	
CELL	21700	
Tests & Certifications	IP X6 CB, CE, UN38.3, ISO 13849	

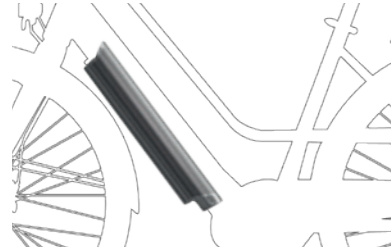

Model No.	BT F020.B504.C BT F021.B504.C	
Dimensions/Size		
A (mm)	434	
B (mm)	67	
C (mm)	74	
Specifications		
Nominal Voltage (Vdc)	36	
Energy (Wh)	504	
Rated Capacity (Ah)	14	
S	10	
P	4	
CELL	18650	
Tests & Certifications	IP X6 CB, CE, UN38.3, ISO 13849 UL2271	



Model No.	BT F010.B630.C	
Dimensions/Size		
A (mm)	398	
B (mm)	74	
C (mm)	83	
Specifications		
Nominal Voltage (Vdc)	36	
Energy (Wh)	630	
Rated Capacity (Ah)	17.5	
S	10	
P	5	
CELL	18650	
Tests & Certifications	IP X6 CB, CE, UN38.3, ISO 13849	



Model No.	BT F15.882.C BT F311.840.0	
Dimensions/Size		
A (mm)	442	
B (mm)	97.6	
C (mm)	90	
Specifications		
Nominal Voltage (Vdc)	36, 48	
Energy (Wh)	882, 840	
Rated Capacity (Ah)	24.5, 17.5	
S	10, 13	
P	7, 5	
CELL	18650	
Tests & Certifications	IP X6 CB, CE, UN38.3, ISO 13849 UL2271	

BATTERY

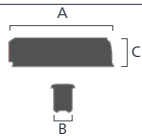

Model No.	BT F38.1008.C
Dimensions/Size	
A (mm)	425
B (mm)	116
C (mm)	97
Specifications	
Nominal Voltage (Vdc)	48
Energy (Wh)	1008
Rated Capacity (Ah)	21
S	13
P	6
CELL	18650
Tests & Certifications	IP X6 UN38.3, MSDS

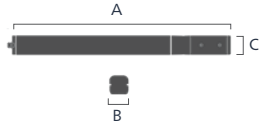

Model No.	BT F041.B360.C.P
Dimensions/Size	
A (mm)	454
B (mm)	48
C (mm)	48
Specifications	
Nominal Voltage (Vdc)	36
Energy (Wh)	360
Rated Capacity (Ah)	10
S	10
P	2
CELL	21700
Tests & Certifications	IP X6 CB, CE, UN38.3, ISO 13849

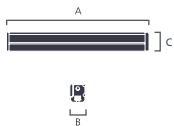

Model No.	BT F014.410.C
Dimensions/Size	
A (mm)	470
B (mm)	63
C (mm)	52
Specifications	
Nominal Voltage (Vdc)	43
Energy (Wh)	410
Rated Capacity (Ah)	9.5
S	12
P	2
CELL	21700
Tests & Certifications	IP X6 CB, CE, UN38.3, ISO 13849

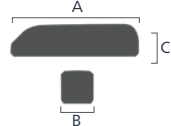

Model No.	BT F150.B630.C
Dimensions/Size	
A (mm)	367
B (mm)	90
C (mm)	93
Specifications	
Nominal Voltage (Vdc)	36
Energy (Wh)	630
Rated Capacity (Ah)	17.5
S	10
P	5
CELL	18650
Tests & Certifications	IP X6 CE, UN38.3, UL2271

BATTERY

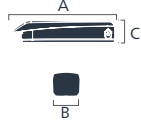

Model No.	BT F07.450.C BT F08.600.C
Dimensions/Size	
A (mm)	334
B (mm)	78, 89
C (mm)	92
Specifications	
Nominal Voltage (Vdc)	43
Energy (Wh)	450, 600
Rated Capacity (Ah)	10.5, 14
S	12
P	3, 4
CELL	18650
Tests & Certifications	IP X6 CB, CE, UN38.3, ISO 13849

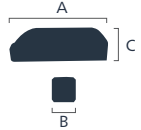

Model No.	BT F23.720.C BT F22.960.C
Dimensions/Size	
A (mm)	334
B (mm)	78, 89
C (mm)	92
Specifications	
Nominal Voltage (Vdc)	50.4
Energy (Wh)	720, 960
Rated Capacity (Ah)	14.3, 19
S	14
P	3, 4
CELL	21700
Tests & Certifications	IP X6 CB, CE, UN38.3, ISO 13849, UL2271, E-Mark, MSDS

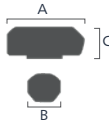

Model No.	BT F420.B252.C.P
Dimensions/Size	
A (mm)	205
B (mm)	88
C (mm)	77.5
Specifications	
Nominal Voltage (Vdc)	36
Energy (Wh)	252
Rated Capacity (Ah)	7
S	10
P	2
CELL	18650
Tests & Certifications	IP X6 CB, CE, MSDS, ISO 13849

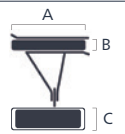

Model No.	BT C01.498.UC.P BT C01.623.UC.P BT C01.750.UC.P
Dimensions/Size	
A (mm)	408
B (mm)	70
C (mm)	123
Specifications	
Nominal Voltage (Vdc)	43
Energy (Wh)	498, 623, 750
Rated Capacity (Ah)	11.6, 14.5, 17.5
S	12
P	4, 5, 5
CELL	18650
Tests & Certifications	IP X6 CB, CE, UN38.3, ISO 13849

SENSOR



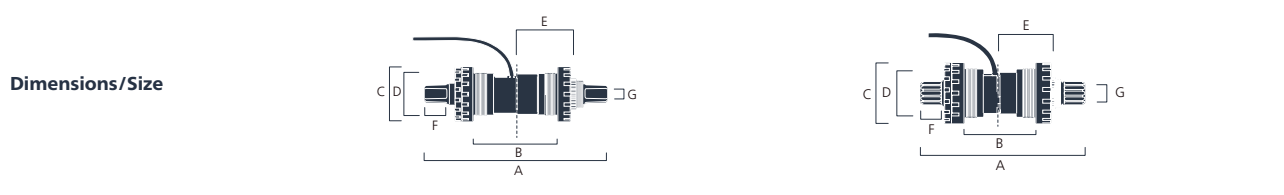

Model No.	SR PA211.32.ST SR PA221.32.ST SR PA231.32.ST SR PA241.32.ST SR PA251.32.ST SR PA261.32.ST	SR PA310.32.ST
------------------	--	----------------



A (mm)	148, 167, 148, 160, 187, 200	155
B (mm)	68, 100, 73, 84, 110, 120	68
C (mm)	2-Ø 44	2-Ø 58
D (mm)	2-BC1.37"*24T	T47
E (mm)	47.5, 63.5, 50, 55.5, 68.5, 73.5	47.5
F (mm)	2-17, 2-17, 2-17, 2-17, 2-15, 2-17	2-13
G (mm)	2-M8*P1*25	2-M15*P1*13
Core Data		
Type	Cadence & Torque	Cadence & Torque
Signals (Pulses/Cycle)	32	32
Shaft Standard	JIS	ISIS
Mounting Parameters		
Mounting Position	Bottom Bracket	Bottom Bracket
Cap Material	Aluminum	Aluminum
Cable Length (mm), Connector Type	150 G6.4.2 / 950 G6.4.2	150 G6.4.2 / 950 G6.4.2
Tests & Certifications		
	IP X5 EN 15194 / EN 14764 / UL2849 / ROHS	IP X5 EN 15194 / EN 14764 / ROHS

SENSOR

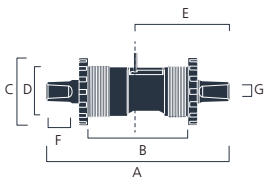
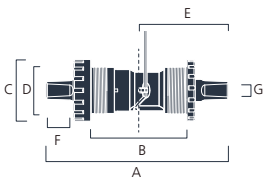

Model No.	SR PA112.32.S SR PA121.32.S SR PA131.32.S SR PA142.32.S	SR PA152.32.S	SR PA051.12.S
Dimensions/Size			
A (mm)	127, 119, 124, 136.5	126, 130	43.8
B (mm)	68, 68, 68, 73	68	54
C (mm)	2 - Ø 45.5	2 - Ø44	9.6
D (mm)	2 - BC1.37"*24T	2 - BC1.37"*24T	Ø15.2
E (mm)	63.8, 57.5, 60.7, 64.3	65.5, 66.3	-
F (mm)	2 - 17	2 - 17	-
G (mm)	2 - M8*P1*25	2 - M8*P1*25	-
Core Data			
Type	Cadence Sensor	Cadence Sensor	Cadence Sensor
Signals (Pulses/Cycle)	32	32	12
Shaft Standard	JIS	JIS	-
Mounting Parameters			
Mounting Position	Bottom Bracket	Bottom Bracket	Bottom Bracket Shaft
Cap Material	Plastic	Aluminum	-
Cable Length (mm), Connector Type	150 G6.5.4 / 950 G6.5.4	150 G6.5.4 / 950 G6.5.4	150 G6.5.4 / 950 G6.5.4
Tests & Certifications	Waterproof: IP X5 Certifications: EN 15194 / EN 14764 / UL2849 / ROHS		

SENSOR



Model No.	SR SD021.01	SR SD071.02	SR 502
Dimensions/ Size			
A (mm)	10 - 20	5 - 10	5 - 10
B (mm)	5.5	10	67
C (mm)	-	18	18
D (mm)	-	16.25	16.25
Core Data			
Type	Wheel Speed Sensor	Wheel Speed Sensor	Wheel Speed Sensor
Mounting Parameters			
Mounting Position	Chain Stay & Spoke	Chain Stay & Disc Brake	Chain Stay & Disc Brake with centerlock
Cable Length(mm), Connector Type	100 G4.3 550 3104A1004 550 G8.5.3	100 G4.3.2 550 G8.5.4	100 G4.3.2 550 G8.5.4
Tests & Certifications	Waterproof: IP X5 Certifications: EN 15194 / ROHS		

CONTROLLER



Model No.	CR S307.1000.FC	CR C101.C	CR A101.C
Dimensions/ Size			
A (mm)	151	109	77
B (mm)	52	56	47
C (mm)	29	34	29
Core Data			
Nominal Voltage (Vdc)	48 / 52, 48 / 52	36 / 43 / 48, 48 / 52	36 / 43 / 48, 36 / 43 / 48
Low Voltage Protection(Vdc)	41 / 44, 41 / 44	32 / 38 / 41, 41 / 44	32 / 38 / 41, 32 / 38 / 41
Current Limit (A)	25 / 21, 30 / 28	25 / 22 / 20, 22 / 20	15 / 13 / 12, 18 / 15 / 14
Rated Power (W)	750, 1000	500, 650	250, 350
Mounting Parameters			
Com. Protocol	CAN	CAN	CAN
E-Brake	Optional	Optional	Optional
Throttle	Optional	Optional	Optional
IOT	Optional	Optional	Optional
Further Specifications			
Walk Assistance (km/h)	4.5	4.5	4.5
Light Drive Capacity (Vdc/W)	12 / 6(max) 6 / 3(max)	12 / 6(max) 6 / 3(max)	12 / 6(max) 6 / 3(max)
Tests & Certifications	Waterproof: IP X6 Certifications: CE / EN 15194 / ROHS / UL2849		

ACCESSORIES

CHAINWHEEL



Model No.	CW G532.1A	CW G532.2A	CW G510.1A	CW G510.1B
Core Data				
Suitability	M820	M820	M620	M620
Teeth Number(XX)	44T	34 - 50T	40T , 42T , 44T , 48T , 52T	40T , 42T , 44T , 52T
Chain Line	49	47	70	48
Thickness(X/XX")	Narrow Wide System	3 / 32"	Narrow Wide System	Narrow Wide System
Spider Style	4 (φ 110)	4 (φ 110)	5 (φ 130)	5 (φ 130)
Chain Guard	N/A	N/A	Optional	Optional



Model No.	CW G522.1A	CW G522.1C	CW G332.1A	CW G332.1B
Core Data				
Suitability	M510 / M560	M510 / M560	M420	M420
Teeth Number(XX)	32T , 40T	34T	38T	38T
Chain Line	53	53	48	45
Thickness(X/XX")	Narrow Wide System	Narrow Wide System	1/8" , 3/32" , 11/128"	1/8" , 3/32" , 11/128"
Spider Style	4 (φ 104)	-	-	4 (φ 104)
Chain Guard	N/A	N/A	N/A	Optional



Model No.	CW G332.1C	CW G333.1B	CW G210.1A
Core Data			
Suitability	M420	M410	M210
Teeth Number(XX)	38T , 42T , 44T	38T	38T , 44T
Chain Line	49	53	49
Thickness(X/XX")	3/32" , 11/128"	Narrow Wide System	3/32" , 11/128"
Spider Style	4 (φ 104)	4 (φ 110)	4 (φ 104)
Chain Guard	Optional	N/A	Optional

ACCESSORIES

CHAINWHEEL



Model No.	CW G210.1B	CW G210.1C	CW G321.1A	CW G341.1A
Core Data				
Suitability	M210	M210	M635	M435 / M225
Teeth Number(XX)	38T , 44T	38T	42T , 46T , 52T	42T , 46T , 52T
Chain Line	45	48	59.6 (68 , 73)	59.6 (68 , 73)
Thickness(X/XX")	1/8" , 3/32" , 11/128"	1/8" , 3/32" , 11/128"	Narrow Wide System	Narrow Wide System
Spider Style	4 (∅ 104)	-	5 (∅ 130)	5 (∅ 130)
Chain Guard	Optional	N/A	N/A	N/A



Model No.	CW PA310.1A	CW PA211.1A	CW PA211.1B	CW PA211.3A
Core Data				
Suitability	SR PA310.32.ST	SR PA2XX.32.ST	SR PA2XX.32.ST	SR PA2XX.32.ST
Teeth Number(XX)	34T , 36T , 38T , 42T , 44T , 48T	34T , 36T , 38T , 42T , 44T , 48T	48T , 50T , 52T	44 - 32 - 22T
Chain Line	47.5(68) , 63.5(100) , 50(73) , 55.5(84) , 68.5(110) , 73.5(120)	47.5(68) , 63.5(100) , 50(73) , 55.5(84) , 68.5(110) , 73.5(120)	47.5(68) , 63.5(100)	55.5 / 48 / 40(68) , 71.5 / 64 / 56(100)
Thickness(X/XX")	1/8" , 3/32" , 11/128"	1/8" , 3/32" , 11/128"	1/8" , 3/32" , 11/128"	3/32"
Spider Style	4 (∅ 104)	4 (∅ 104)	5 (∅ 130)	4 (∅ 64) , 4 (∅ 104)
Chain Guard	Optional	Optional	Optional	N/A

ACCESSORIES

CRANK



Model No.	CK ISIS01.170P / 165P
Core Data	
Shaft standard	ISIS
Suitability	M820 (MTB / Road)



Model No.	CK ISIS02.170P
Core Data	
Shaft standard	ISIS
Suitability	M620 (Fat)



Model No.	CK ISIS03.170P
Core Data	
Shaft standard	ISIS
Suitability	M620 (Cargo)



Model No.	CK BF01.170P
Core Data	
Shaft standard	BAFANG
Suitability	M560 / M510 / M420



Model No.	CK BF02.170P / 165P
Core Data	
Shaft standard	BAFANG
Suitability	M560 / M510 / M420



Model No.	CK JIS01.170P
Core Data	
Shaft standard	JIS
Suitability	M410 / M210 / M635 / M435 / M225



Model No.	CK JIS02.170P
Core Data	
Shaft standard	JIS
Suitability	M410 (Fat)



Model No.	CK JIS03.170P
Core Data	
Shaft standard	JIS
Suitability	M210

THROTTLE



Model No.	TR B01.R.T
Mounting Parameters	
Type	Thumb , Right
Holder (mm)	Ø 22.2
Cable Length (mm), Connection Type	200 M3.10
Tests & Certifications	
Waterproof	IP X5
Certifications	Reach / ROHS / UL2849

E-BRAKE



Model No.	BR G03.M
Mounting Parameters	
Holder (mm)	Ø 22.2
Cable Length (mm), Connection Type	250 G3.10
Tests & Certifications	
Waterproof	IP X5
Certifications	Reach / ROHS / UL2849

ACCESSORIES

MOTOR COVER



Model No.	MD G532.A	MD G532.B	MD G510.A	MD G521.A
Core Data				
Material	PC	PC	PC	PC
Suitability	M820 (FP MMG532.A)	M820 (FP MMG532.B)	M620	M560 / M510 (FP MMG521.A)
Color	Black	Black	Black	Black



Model No.	MD G521.B	MD G522.A	MD G332.A	MD G333.A
Core Data				
Material	PC	PC	PC	PC
Suitability	M560 (FP MMG521.B)	M510 (FP MMG521.B)	M420	M410 (FP MMG521.A)
Color	Black	Black	Black / Silver Gray	Black



Model No.	MD G333.B	MD G210.A
Core Data		
Material	PC	PC
Suitability	M410 (FP MMG521.B)	M210
Color	Black	Black

ACCESSORIES

FIXATION PARTS



Model No.	FP MMG532.A	FP MMG532.B	FP MMG510.A	FP MMG521.A
Core Data				
Suitability	M820	M820	M620	M560 / M510 / M410



Model No.	FP MMG521.B	FP MMG332.A	FP MMG2300.A
Core Data			
Suitability	M560 / M510 / M410	M420	M210

BASH GUARD



Model No.	BG G532.A	BG G521.A	BG G521.B	BG G333.A
Core Data				
Material	PC	PC	PC	PC
Suitability	M820	M560 / M510 (FP MMG521.A)	M560 / M510 (FP MMG521.B)	M410 (FP MMG521.A)
Color	Black	Black	Black	Black



Model No.	BG G333.B
Core Data	
Material	PC
Suitability	M410 (FP MMG521.B)
Color	Black

Please note: Specifications are for reference, and subject to change without prior notice, for detail data, pls confirm with sales staff.

BESST Pro

BAFANG E-MOBILITY SALES & SERVICE TOOL

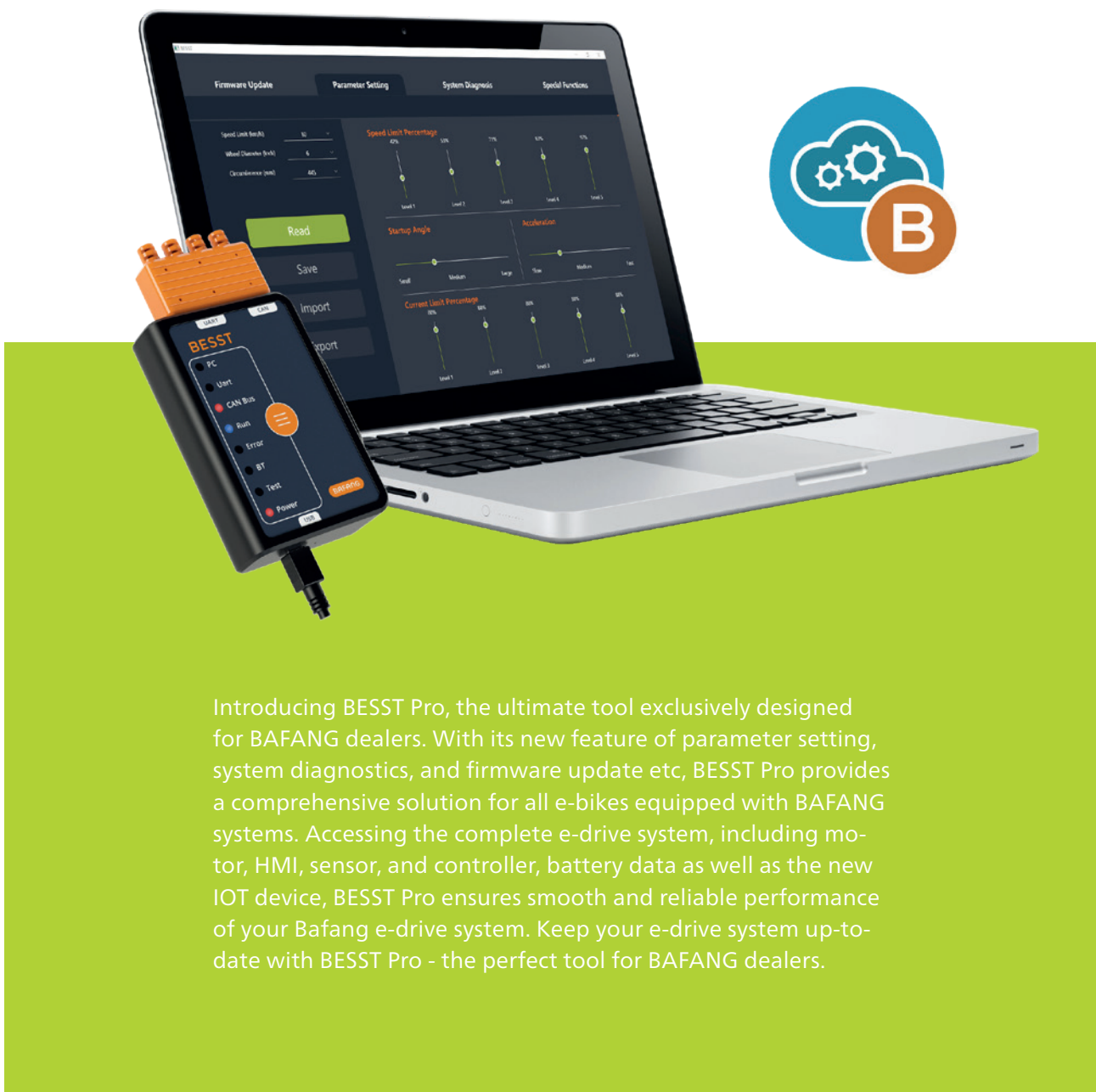

Introducing BESST Pro, the ultimate tool exclusively designed for BAFANG dealers. With its new feature of parameter setting, system diagnostics, and firmware update etc, BESST Pro provides a comprehensive solution for all e-bikes equipped with BAFANG systems. Accessing the complete e-drive system, including motor, HMI, sensor, and controller, battery data as well as the new IOT device, BESST Pro ensures smooth and reliable performance of your Bafang e-drive system. Keep your e-drive system up-to-date with BESST Pro - the perfect tool for BAFANG dealers.

BAFANG

POWER YOUR LIFE



ASIA

China Headquarter

Bafang Electric (Suzhou) Co., Ltd.
No.6 Dongyanli Rd., Suzhou Industrial
Park 215125, Suzhou

China

Bafang New Energy (Suzhou) Co., Ltd.
Building 1, 3E Industrial Park, No. 18,
Chunyao Road, Caohu Community
215144, Suzhou

Bafang (Tianjin) Electric Technology
Co., Ltd.
No. 21 Yin Hai Road, High-tech Industrial
Park, 301600, Jinghai, Tianjin

Bafang (Guangdong) Electric Technology
Co., Ltd.
Floor 2-4, Building 6, Walden Science
Park, Shengfeng Group Phase II, Julong
Village, Yuanzhou Town, Boluo County
516123, Huizhou, Guangdong

Bafang Electric (Suzhou) Co., Ltd. /
Taiwan Office
8F.-23, No.156, Gaotie 5th Rd., Wuri Dist.,
Taichung City 414-56, Taiwan

EUROPE

The Netherlands

Bafang Electric Motor
Science-Technology B.V.
Bijsterhuizen 2415,
6604 LK Wijchen

Germany

Bafang Electric GmbH
Johannes-Liemke-Straße 2
33161 Hövelhof

Poland

Bafang Electric (Poland) sp. z o.o.
Ul. Logistyczna 8
55-040 Bielany Wroclawskie, Wroclaw

France

Bafang Electric France Branch
4 Bis Rue du Bois Briard
91080 Courcouronnes

Italy

Bafang Electric Italy Branch
Via Luigi Pierobon, n. 107
35010 Limena (PD)

Denmark

Bafang Electric Nordic Branch
Paul Bergsøes Vej 16
2600 Glostrup

AMERICA

USA

Bafang Science Inc.
2530 E. Corporate PL, suite A100,
Monterey Park, CA 91754

➤ sales@bafang-e.com
➤ www.bafang-e.com



Printed in Germany | Errors and omissions excepted.
© June 2023 Bafang Electric (Suzhou) Co., Ltd.

@BafangElectric     